

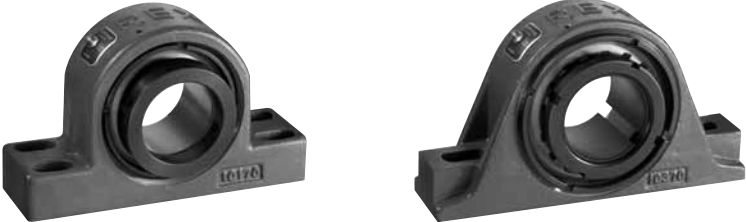



Rexnord
|||||

Mill Duty Bearings

TABLE OF CONTENTS

Page	PILLOW BLOCKS	
RSEP Type E 1000 Series		.4
RSP 1000 Series5
RSDP 8000 Series10
RSSN 8000 Series13
FLANGE CARTRIDGE BLOCKS		
RBR 1000 Series		.6
RSFS 1000 Series7
RSDR 8000 Series11
FLANGE BLOCKS		
RSEF Type E 1000 Series		.8
RSF 1000 Series9
RSDF 8000 Series12
REPLACEMENT KITS		
1000 Series		.17
8000 Series17
Bearing Mounting Procedures .14		
Installation14-15
Radial Load Rating Table16

TRIPLE CONTACT GUARDED SEAL

- Excellent for low and high speeds
- For clean or dirty conditions

TWO MOUNTING STYLES AVAILABLE

- Eccentric mount
- Adapter mount

RUGGED CAST STEEL HOUSINGS

- 80,000 PSI tensile strength
- Guaranteed for life

THREADED RING

- Allows for easy change from fixed to floating bearing
- Floating bearings allow for 1/8" total axial movement

PILLOW BLOCK ENDS ARE MILLED

- For accurate location surfaces

SOLID MACHINED PILLOW BLOCK BASE

- For additional strength

SIMPLE AND ECONOMICAL TO REBUILD

- Replacement bearing kits available

±1.5° DYNAMIC MISALIGNMENT

Self-aligning, double-row, spherical roller bearings allow for static and dynamic misalignment conditions that exist in every bearing application.

Cast steel housing with a tensile strength of 80,000 psi to provide the ultimate in fracture resistance

Type "R" triple contact seal

- Fine particulate protection
- Moderate speed
- External "Chip" guard

Threaded ring

- Positive bearing positioning
- Allows for easy change from fixed to floating
- 1/8" Expansion Capability

External heavy gauge steel "chip" guard for large particle protection

Floating seal accommodates high misalignment

- Maintains full lip contact

Bronze retainer

- For superior strength and roller guidance

Two nitrile rubber positive contacting lips to seal out fine particulates

1000 SERIES ECCENTRIC LOCKING COLLAR

- Accommodates undersize shafting
- Holds tight in demanding applications where vibration and shock loads are present

8000 SERIES ADAPTER MOUNT

SAME FEATURES AS 1000 SERIES PLUS **Extra Heavy Duty**

- Full bore contact for maximum shaft holding power, concentricity and running accuracy
- Accommodates undersize shafting
- Increased load capacity

For high performance and critical applications we recommend the premium Rex Roller Bearing in 2000, 3000, 5000 or 9000 series. Contact the Rexnord Bearing Group for application engineering assistance at 317-273-5500.

R S EP 1 207 F EX

Seal Type	R	Triple contact guarded seal
------------------	---	-----------------------------

Housing Material	S	Cast steel
-------------------------	---	------------

Housing Type	BR	Flange cartridge unit
	DF	Flange unit - DV interchange
	DP	Pillow block - DV interchange
	DR	Flange cartridge unit - DV interchange
	EF	Flange unit - Type E interchange
	EP	Pillow block - Type E interchange
	FS	Flange cartridge unit
	F	Flange unit
	P	Pillow block
SN	Pillow block - interchange	

Bearing Type	1	1000 Series, Medium duty eccentric lock
	8	8000 Series, Heavy duty adapter mounted

Shaft Diameter	207	27/16 - last two digits in 16ths of an inch
	55MM	55 millimeter

Mounting Options	None	Pillow block with 2 mounting bolts
	F	Pillow block with 4 mounting bolts
	H	Reversed assembly of bearing in the housing

Expansion unit	EX	Expansion unit designation
-----------------------	----	----------------------------

EXAMPLES

- RSEF1315 Complete flange bearing with dual lip seals, eccentric mount bearing for a 3 15/16 shaft size in a steel housing.
- To rebuild the above RSEF1315 bearing use the 1315U bearing replacement kit and the RS1400 seal kit and the TC1400 cover kit.

RSEP ECCENTRIC LOCK

Mill Duty Bearings

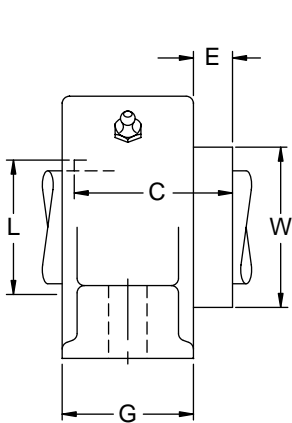

TWO BOLT

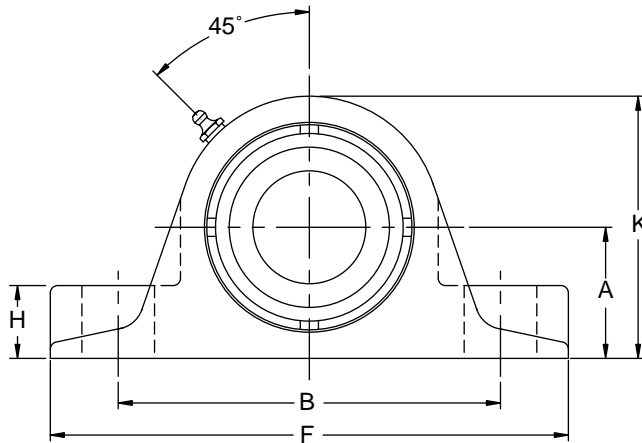

FOUR BOLT

Shaft Size Inches	Complete Fixed Bearing Block No.	Dimension in Inches												Bolts		Complete Block Net Wt. Lbs.
		A ±0.005	B		C [▲]	E [#]	F [*]	G	H	I	K	L	W	No.	Size	
			Min	Max												
TWO BOLT HOUSINGS																
1 ¹⁵ / ₁₆	RSEP-1115	2 ¹ / ₄	6	7 ¹ / ₈	2 ²³ / ₃₂	1 ⁹ / ₃₂	8 ⁷ / ₈	2 ⁷ / ₁₆	1 ¹ / ₄	...	4 ¹ / ₂	2 ⁵ / ₁₆	2 ³ / ₄	2	5 ⁵ / ₈	13.2
2 ³ / ₁₆	RSEP-1203	2 ¹ / ₂	6 ¹ / ₂	7 ⁷ / ₈	3 ¹³ / ₆₄	6 ¹ / ₆₄	9 ⁵ / ₈	2 ¹ / ₂	1 ³ / ₈	...	5	2 ⁵ / ₈	3 ¹ / ₄	2	5 ⁵ / ₈	14.3
2 ⁷ / ₁₆ 2 ¹ / ₂	RSEP-1207 RSEP-1208	2 ³ / ₄	6 ⁷ / ₈	8 ⁵ / ₈	3 ⁵ / ₃₂	2 ⁷ / ₃₂	10 ¹ / ₄	2 ⁹ / ₁₆	1 ³ / ₈	...	5 ⁹ / ₁₆	3 ⁷ / ₆₄	3 ⁹ / ₁₆	2	5 ⁵ / ₈	19.8
2 ¹⁵ / ₁₆ 3	RSEP-1215 RSEP-1300	3 ¹ / ₈	7 ⁷ / ₈	9 ⁵ / ₈	3 ¹³ / ₃₂	1 ⁵ / ₁₆	11 ³⁹ / ₆₄	2 ⁵ / ₈	1 ³ / ₈	...	6 ¹ / ₄	3 ³ / ₈	4 ³ / ₆₄	2	3 ³ / ₄	25.3
3 ⁷ / ₁₆	RSEP-1307	3 ³ / ₄	9 ³ / ₈	11 ¹ / ₄	3 ²⁷ / ₃₂	6 ³ / ₆₄	13 ¹ / ₂	3 ¹ / ₈	1 ⁷ / ₈	...	7 ¹³ / ₃₂	3 ³¹ / ₃₂	4 ⁴⁹ / ₆₄	2	7 ⁷ / ₈	41.8
3 ¹⁵ / ₁₆	RSEP-1315	4 ¹ / ₈	10 ³ / ₆₄	12 ⁵ / ₈	4 ⁷ / ₁₆	3 ¹ / ₃₂	14 ¹ / ₄	3 ⁷ / ₈	2	...	8 ¹ / ₄	4 ⁹ / ₁₆	5 ⁵ / ₈	2	1	58.3
FOUR BOLT HOUSINGS																
2 ⁷ / ₁₆ 2 ¹ / ₂	RSEP-1207F RSEP-1208F	2 ³ / ₄	7 ¹ / ₈	8 ³ / ₄	3 ⁵ / ₃₂	3 ¹ / ₆₄	10 ¹ / ₄	3 ¹ / ₄	1 ¹ / ₂	1 ⁷ / ₈	5 ⁹ / ₁₆	3 ⁷ / ₆₄	3 ⁹ / ₁₆	4	5 ⁵ / ₈	26.2
2 ¹⁵ / ₁₆ 3	RSEP-1215F RSEP-1300F	3 ¹ / ₈	8	9 ¹⁹ / ₃₂	3 ¹³ / ₃₂	9 ¹ / ₁₆	10 ⁵³ / ₆₄	3 ³ / ₈	1 ¹¹ / ₁₆	2 ¹ / ₈	6 ¹ / ₄	3 ³ / ₈	4 ³ / ₆₄	4	5 ⁵ / ₈	32.2
3 ⁷ / ₁₆	RSEP-1307F	3 ³ / ₄	9 ¹ / ₄	11 ¹ / ₄	3 ²⁷ / ₃₂	4 ³ / ₆₄	13 ⁵ / ₈	3 ³ / ₄	1 ⁷ / ₈	2 ³ / ₈	7 ³⁹ / ₆₄	3 ³¹ / ₃₂	4 ⁴⁹ / ₆₄	4	3 ³ / ₄	50.9
3 ¹⁵ / ₁₆	RSEP-1315F	4 ¹ / ₄	10 ²⁹ / ₃₂	13 ³ / ₈	4 ⁷ / ₁₆	3 ¹ / ₄	14 ⁷ / ₈	4 ⁵ / ₁₆	2	2 ¹ / ₄	8 ⁹ / ₁₆	4 ⁹ / ₁₆	5 ⁵ / ₈	4	3 ³ / ₄	66.0
FOUR BOLT HOUSING ADAPTER MOUNT																
4 ⁷ / ₁₆	RSEP-8407F	4 ³ / ₄	11 ²⁹ / ₃₂	14 ¹ / ₂	5 ¹³ / ₆₄	4 ⁹ / ₆₄	16 ¹ / ₈	4 ³ / ₄	2	2 ¹ / ₂	9 ⁴⁵ / ₆₄	5 ³ / ₄	6 ⁹ / ₁₆	4	3 ³ / ₄	87.4

▲Length along shaft.

#Dimensions for fixed bearings. For expansion bearings add 1/8 inch maximum.

*Length along base is machined.

Add EX suffix for expansion bearings with 1/8 inch movement (example RSEP1215EX)

**Interchange guide is for comparison only.

RSP ECCENTRIC LOCK

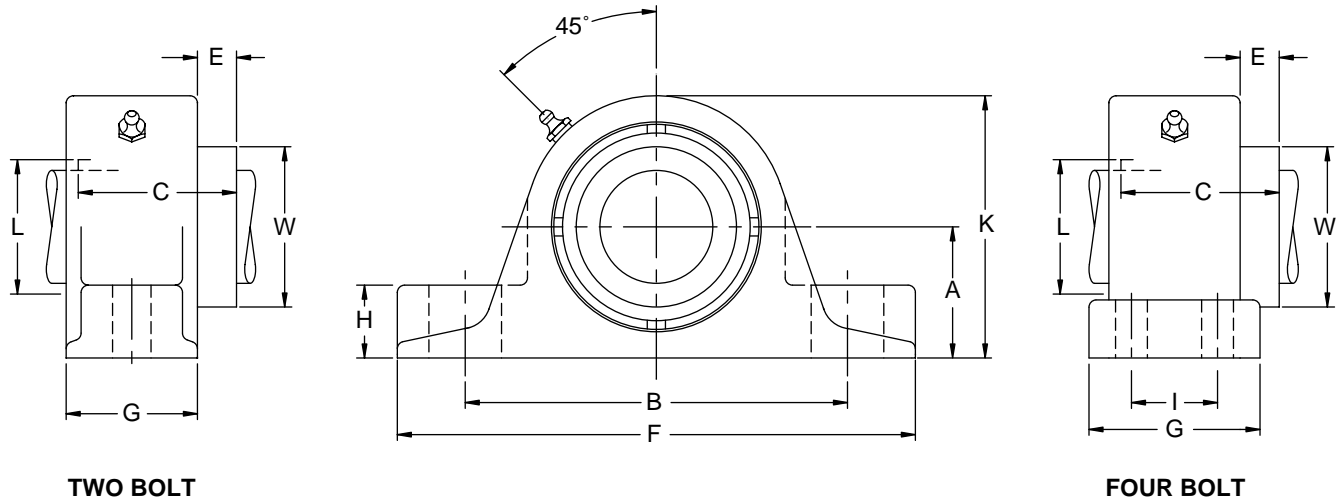

Shaft Size Inches	Complete Fixed Bearing Block No.	Dimension in Inches											Bolts		Complete Block Net Wt. Lbs.	
		A ±0.005	B		C [▲]	E [#]	F [*]	G	H	I	K	L	W	No.		Size
TWO BOLT HOUSINGS																
1 ¹⁵ / ₁₆	RSP-1115	2 ¹ / ₄	5 ¹⁵ / ₁₆	6 ²³ / ₆₄	2 ²³ / ₃₂	2 ³ / ₃₂	8 ³ / ₈	2 ⁷ / ₁₆	1 ¹ / ₄	...	4 ⁹ / ₁₆	2 ⁵ / ₁₆	2 ³ / ₄	2	5 ⁵ / ₈	12.7
2 ³ / ₁₆	RSP-1203	2 ¹ / ₂	6 ¹ / ₂	7 ¹ / ₁₆	3 ¹³ / ₆₄	6 ¹ / ₆₄	8 ⁷ / ₈	2 ¹ / ₂	1 ³ / ₈	...	5	2 ⁵ / ₈	3 ¹ / ₄	2	5 ⁵ / ₈	13.2
2 ⁷ / ₁₆ 2 ¹ / ₂	RSP-1207 RSP-1208	2 ³ / ₄	6 ¹³ / ₁₆	7 ⁷ / ₁₆	3 ⁵ / ₃₂	7 ⁷ / ₈	9 ¹ / ₄	2 ⁹ / ₁₆	1 ³ / ₈	...	5 ¹ / ₂	3 ⁷ / ₆₄	3 ⁹ / ₁₆	2	5 ⁵ / ₈	19.3
2 ¹⁵ / ₁₆ 3	RSP-1215 RSP-1300	3 ¹ / ₄	7 ⁴⁵ / ₆₄	8 ¹³ / ₃₂	3 ¹³ / ₃₂	6 ³ / ₆₄	10 ⁷ / ₁₆	2 ³⁵ / ₆₄	1 ³ / ₈	...	6 ⁷ / ₁₆	3 ³ / ₈	4 ³ / ₆₄	2	3 ³ / ₄	24.2
3 ⁷ / ₁₆	RSP-1307	3 ³ / ₄	9 ¹ / ₄	10 ⁹ / ₄	3 ²⁷ / ₃₂	1 ³ / ₆₄	13	3 ¹ / ₈	1 ⁷ / ₈	...	7 ¹ / ₂	3 ³¹ / ₃₂	4 ⁴⁹ / ₆₄	2	7 ⁷ / ₈	39.6
3 ¹⁵ / ₁₆	RSP-1315	4 ¹ / ₄	10 ³ / ₆₄	12 ³⁹ / ₆₄	4 ⁷ / ₁₆	5 ³ / ₆₄	14 ¹ / ₄	3 ⁷ / ₈	2 ¹ / ₈	...	8 ¹³ / ₃₂	4 ⁹ / ₁₆	5 ⁵ / ₈	2	1	56.1
FOUR BOLT HOUSINGS																
2 ⁷ / ₁₆ 2 ¹ / ₂	RSP-1207F RSP-1208F	2 ³ / ₄	6 ⁷ / ₈	7 ⁵ / ₈	3 ⁵ / ₃₂	3 ⁹ / ₆₄	9 ¹ / ₄	3	1 ¹ / ₂	1 ³ / ₄	5 ⁹ / ₁₆	3 ⁷ / ₆₄	3 ⁹ / ₁₆	4	5 ⁵ / ₈	26.2
2 ¹⁵ / ₁₆ 3	RSP-1215F RSP-1300F	3 ¹ / ₄	7 ³⁹ / ₆₄	9 ⁷ / ₆₄	3 ¹³ / ₃₂	1 ¹ / ₁₆	10 ⁷ / ₁₆	3 ¹ / ₈	1 ¹¹ / ₁₆	1 ⁷ / ₈	6 ³ / ₈	3 ³ / ₈	4 ³ / ₆₄	4	5 ⁵ / ₈	32.2
3 ⁷ / ₁₆	RSP-1307F	3 ³ / ₄	8 ⁷ / ₈	10 ⁷ / ₈	3 ²⁷ / ₃₂	1 ¹ / ₁₆	12 ¹⁹ / ₆₄	3 ³ / ₄	1 ⁷ / ₈	2	7 ³⁹ / ₆₄	3 ³¹ / ₃₂	4 ⁴⁹ / ₆₄	4	3 ³ / ₄	50.9
3 ¹⁵ / ₁₆	RSP-1315F	4 ¹ / ₄	10 ²⁹ / ₃₂	13 ³ / ₈	4 ⁷ / ₁₆	3 ³ / ₄	14 ⁷ / ₈	4 ⁵ / ₁₆	2	2 ¹ / ₄	8 ⁹ / ₁₆	4 ⁹ / ₁₆	5 ⁵ / ₈	4	3 ³ / ₄	66.0
FOUR BOLT HOUSING ADAPTER MOUNT																
4 ⁷ / ₁₆	RSP-8407F	4 ³ / ₄	11 ²⁹ / ₃₂	14 ¹ / ₂	5 ¹³ / ₆₄	4 ⁹ / ₆₄	16 ¹ / ₈	4 ³ / ₄	2	2 ¹ / ₂	9 ⁴⁵ / ₆₄	5 ³ / ₄	6 ⁹ / ₁₆	4	3 ³ / ₄	87.4

▲Length along shaft.
 #Dimensions for fixed bearings. For expansion bearings add 1/8 inch maximum.
 *Length along base is machined.
 Add EX suffix for expansion bearings with 1/8 inch movement (example RSP1215EX)
 **Interchange guide is for comparison only.



RSBR ECCENTRIC LOCK

Mill Duty Bearings

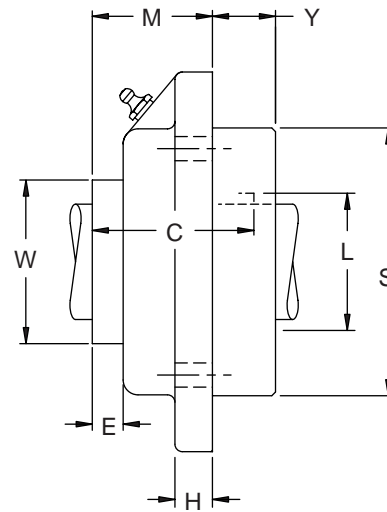
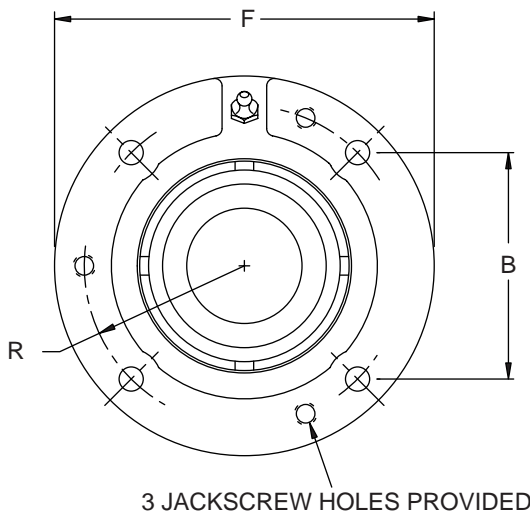

Shaft Size Inches	Complete Fixed Bearing Block No.	Dimension in Inches											Bolts		Complete Block Net Wt. Lbs.	
		B	C [▲]	E [#]	F	H	M	R	S +0.000 -0.002	L	W	Y	No.	Size		
FOUR BOLT HOUSING																
1 ¹⁵ / ₁₆	RSBR-1115	3 ⁵¹ / ₆₄	2 ²³ / ₃₂	1 ⁷ / ₃₂	6 ³ / ₈	5/ ₈	2 ¹ / ₃₂	2 ¹¹ / ₁₆	4 ¹ / ₂	2 ⁵ / ₁₆	2 ³ / ₄	1 ¹ / ₁₆	4	3/ ₈	11.0	
2 ³ / ₁₆	RSBR-1203	4 ¹ / ₄	3 ¹³ / ₆₄	7/ ₈	7 ¹⁹ / ₆₄	2 ¹ / ₃₂	2 ²⁵ / ₆₄	3	5	2 ⁵ / ₈	3 ¹ / ₄	1 ¹ / ₈	4	1/ ₂	14.3	
2 ⁷ / ₁₆ 2 ¹ / ₂	RSBR-1207 RSBR-1208	4 ¹⁹ / ₃₂	3 ⁵ / ₃₂	4 ⁹ / ₆₄	7 ²⁵ / ₃₂	1 ¹ / ₁₆	2 ²⁷ / ₆₄	3 ¹ / ₄	5 ¹ / ₂	3 ⁷ / ₆₄	3 ⁹ / ₁₆	1 ¹ / ₈	4	1/ ₂	16.5	
2 ¹⁵ / ₁₆ 3	RSBR-1215 RSBR-1300	5 ¹⁹ / ₆₄	3 ¹³ / ₃₂	2 ⁷ / ₃₂	8 ³ / ₄	1 ³ / ₁₆	2 ²⁹ / ₆₄	3 ³ / ₄	6 ³ / ₈	3 ³ / ₈	4 ³ / ₆₄	1 ¹ / ₄	4	5/ ₈	23.1	
3 ⁷ / ₁₆	RSBR-1307	6 ³ / ₃₂	3 ²⁷ / ₃₂	2 ⁹ / ₃₂	10 ¹¹ / ₃₂	1	2 ²⁹ / ₃₂	4 ⁵ / ₁₆	7 ³ / ₈	3 ³¹ / ₃₂	4 ⁴⁹ / ₆₄	1 ⁵ / ₁₆	4	3/ ₄	36.3	
3 ¹⁵ / ₁₆	RSBR-1315	6 ⁵ / ₈	4 ⁷ / ₁₆	7/ ₈	10 ⁷ / ₈	1	2 ¹³ / ₁₆	4 ¹¹ / ₁₆	8 ¹ / ₈	4 ⁹ / ₁₆	5 ⁵ / ₈	2 ¹ / ₈	4	3/ ₄	56.1	
SIX BOLT HOUSING ADAPTER MOUNT†																
4 ⁷ / ₁₆	RSBR-8407	5 ⁷ / ₈	5 ¹³ / ₆₄	4 ⁹ / ₆₄	13 ¹ / ₂	1	3 ³¹ / ₆₄	5 ⁷ / ₈	10 ¹ / ₄	5 ³ / ₄	6 ⁹ / ₁₆	1 ²⁹ / ₃₂	6	3/ ₄	70.4	

▲Length along shaft.

#Dimensions for fixed bearings. For expansion bearings add 1/8 inch maximum.

Add EX suffix for expansion bearings with 1/8 inch movement (example RSBR1215EX)

**Interchange guide is for comparison only.

†Not shown above.

RSFS ECCENTRIC LOCK

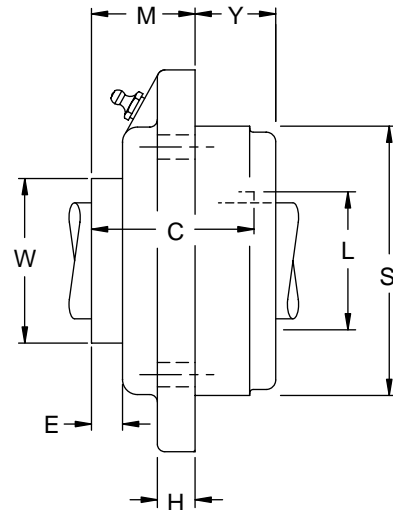
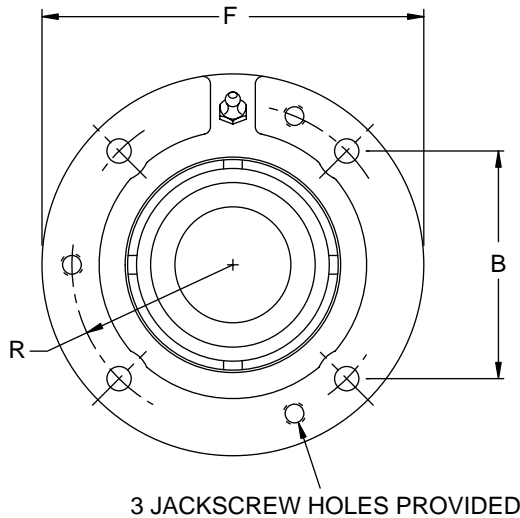

Shaft Size Inches	Complete Fixed Bearing Block No.	Dimension in Inches											Bolts		Complete Block Net Wt. Lbs.	
		B	C [▲]	E [#]	F	H	M	R	S +0.000 -0.002	L	W	Y	No.	Size		
FOUR BOLT HOUSING																
1 ¹⁵ / ₁₆	RSFS-1115	3 ⁵¹ / ₆₄	2 ²³ / ₃₂	1 ⁷ / ₃₂	6 ³ / ₈	3/8	1 ¹⁹ / ₃₂	2 ¹¹ / ₁₆	4 ¹ / ₂	2 ⁵ / ₁₆	2 ³ / ₄	1 ¹ / ₂	4	3/8	11.0	
2 ³ / ₁₆	RSFS-1203	4 ¹ / ₄	3 ¹³ / ₆₄	7/8	7 ¹ / ₈	1/2	1 ⁷ / ₈	3	5	2 ⁵ / ₈	3 ¹ / ₄	1 ⁵ / ₈	4	1/2	14.3	
2 ⁷ / ₁₆ 2 ¹ / ₂	RSFS-1207 RSFS-1208	4 ¹⁹ / ₃₂	3 ⁵ / ₃₂	4 ⁹ / ₆₄	7 ⁵ / ₈	1/2	1 ⁴⁵ / ₆₄	3 ¹ / ₄	5 ¹ / ₂	3 ⁷ / ₆₄	3 ⁹ / ₁₆	1 ³ / ₄	4	1/2	16.5	
2 ¹⁵ / ₁₆ 3	RSFS-1215 RSFS-1300	5 ¹⁹ / ₆₄	3 ¹³ / ₃₂	2 ⁷ / ₃₂	8 ³ / ₄	1/2	1 ¹³ / ₁₆	3 ³ / ₄	6 ³ / ₈	3 ³ / ₈	4 ³ / ₆₄	1 ⁷ / ₈	4	5/8	23.1	
3 ⁷ / ₁₆	RSFS-1307	6 ³ / ₃₂	3 ²⁷ / ₃₂	2 ⁹ / ₃₂	10 ¹ / ₄	7/8	2 ²¹ / ₆₄	4 ⁵ / ₁₆	7 ³ / ₈	3 ³¹ / ₃₂	4 ⁴⁹ / ₆₄	1 ⁷ / ₈	4	3/4	36.3	
3 ¹⁵ / ₁₆	RSFS-1315	6 ⁵ / ₈	4 ⁷ / ₁₆	7/8	10 ⁷ / ₈	1	2 ¹¹ / ₁₆	4 ¹¹ / ₁₆	8 ¹ / ₈	4 ⁹ / ₁₆	5 ⁵ / ₈	2 ¹ / ₄	4	3/4	56.1	
SIX BOLT HOUSING ADAPTER MOUNT†																
4 ⁷ / ₁₆	RSFS-8407	5 ⁷ / ₈	5 ¹³ / ₆₄	1 ¹ / ₆₄	13 ¹ / ₂	1	2 ²⁹ / ₆₄	5 ⁷ / ₈	10 ¹ / ₄	5 ³ / ₄	6 ⁹ / ₁₆	2 ⁵⁹ / ₆₄	6	3/4	70.4	

▲Length along shaft.

#Dimensions for fixed bearings. For expansion bearings add 1/8 inch maximum.

Add EX suffix for expansion bearings with 1/8 inch movement (example RSFS1215EX)

**Interchange guide is for comparison only.

†Not shown above.



RSEF ECCENTRIC LOCK

Mill Duty Bearings

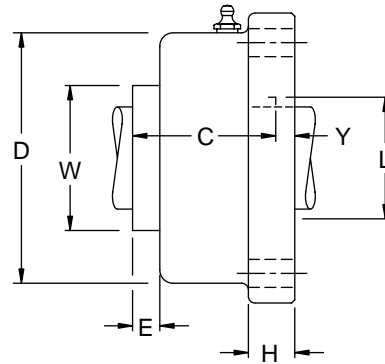
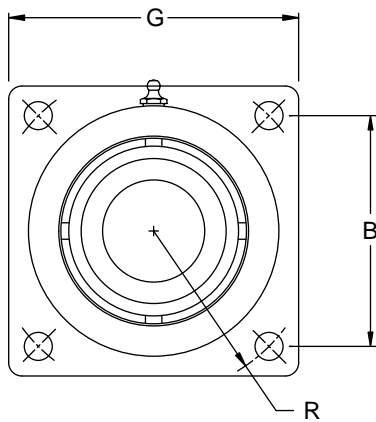

Shaft Size Inches	Complete Fixed Bearing Block No.	Dimension in Inches										Bolts		Complete Block Net Wt. Lbs.
		B	C [▲]	D	G	H	E [#]	R	L	W	Y	No.	Size	
FOUR BOLT HOUSING														
1 ¹⁵ / ₁₆	RSEF-1115	4 ³ / ₈	2 ²³ / ₃₂	4 ³ / ₄	5 ¹ / ₂	7 ⁷ / ₈	1 ¹⁷ / ₃₂	3 ³ / ₃₂	2 ⁵ / ₁₆	2 ³ / ₄	3 ³ / ₈	4	1 ¹ / ₂	12.1
2 ³ / ₁₆	RSEF-1203	4 ⁷ / ₈	3 ¹³ / ₆₄	5 ¹ / ₄	6 ³ / ₁₆	1	7 ⁷ / ₈	3 ²⁹ / ₆₄	2 ⁵ / ₈	3 ¹ / ₄	5 ⁵ / ₁₆	4	5 ⁵ / ₈	15.4
2 ⁷ / ₁₆ 2 ¹ / ₂	RSEF-1207 RSEF-1208	5 ³ / ₈	3 ⁵ / ₃₂	5 ³ / ₄	6 ⁵ / ₈	1	4 ⁴⁹ / ₆₄	3 ⁵¹ / ₆₄	3 ⁷ / ₆₄	3 ⁹ / ₁₆	1 ⁹ / ₆₄	4	5 ⁵ / ₈	18.7
2 ¹⁵ / ₁₆ 3	RSEF-1215 RSEF-1300	6	3 ¹³ / ₃₂	6 ²¹ / ₃₂	7 ⁷ / ₁₆	1 ¹ / ₁₆	5 ⁵⁵ / ₆₄	4 ¹ / ₄	3 ³ / ₈	4 ³ / ₆₄	1 ⁹ / ₆₄	4	3 ³ / ₄	28.6
3 ⁷ / ₁₆	RSEF-1307	7	3 ²⁷ / ₃₂	7 ⁵ / ₈	8 ⁵ / ₈	1 ⁵ / ₁₆	2 ²⁹ / ₃₂	4 ⁶¹ / ₆₄	3 ³¹ / ₃₂	4 ⁴⁹ / ₆₄	3 ³ / ₈	4	3 ³ / ₄	40.7
3 ¹⁵ / ₁₆	RSEF-1315	7 ³ / ₄	4 ⁷ / ₁₆	8 ¹ / ₂	9 ²⁹ / ₃₂	1 ¹ / ₂	7 ⁷ / ₈	5 ³¹ / ₆₄	4 ⁹ / ₁₆	5 ⁵ / ₈	1 ¹ / ₂	4	7 ⁷ / ₈	56.1
FOUR BOLT HOUSING ADAPTER MOUNT														
4 ⁷ / ₁₆	RSEF-8407	8 ³ / ₄	5 ¹³ / ₆₄	10	10 ⁷ / ₈	1 ¹ / ₂	5 ⁷ / ₆₄	6 ³ / ₁₆	5 ³ / ₄	6 ⁹ / ₁₆	1 ¹ / ₁₆	4	7 ⁷ / ₈	70.4

▲Length along shaft.

#Dimensions for fixed bearings. For expansion bearings add 1/8 inch maximum.

Add EX suffix for expansion bearings with 1/8 inch movement (example RSEF1215EX)

**Interchange guide is for comparison only.

RSF ECCENTRIC LOCK

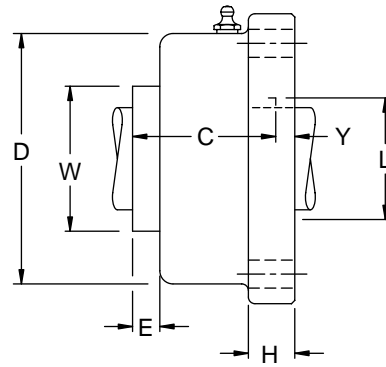
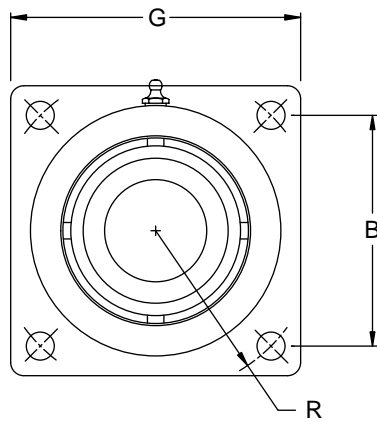

Shaft Size Inches	Complete Fixed Bearing Block No.	Dimension in Inches										Bolts		Complete Block Net Wt. Lbs.
		B	C [▲]	D	G	H	E [#]	R	L	W	Y	No.	Size	
FOUR BOLT HOUSING														
1 ¹⁵ / ₁₆	RSF-1115	4 ¹ / ₁₆	2 ²³ / ₃₂	4 ³ / ₄	5 ³ / ₁₆	2 ⁹ / ₃₂	1 ⁷ / ₃₂	2 ⁷ / ₈	2 ⁵ / ₁₆	2 ³ / ₄	1 ⁵ / ₃₂	4	1/2	12.1
2 ³ / ₁₆	RSF-1203	4 ¹ / ₂	3 ¹³ / ₆₄	5 ³ / ₁₆	5 ⁷ / ₈	3/4	7/8	3 ³ / ₁₆	2 ⁵ / ₈	3 ¹ / ₄	5/16	4	5/8	14.3
2 ⁷ / ₁₆ 2 ¹ / ₂	RSF-1207 RSF-1208	4 ⁴⁹ / ₆₄	3 ⁵ / ₃₂	5 ³ / ₄	6 ³ / ₁₆	1	4 ⁹ / ₆₄	3 ³ / ₈	3 ⁷ / ₆₄	3 ⁹ / ₁₆	1 ⁹ / ₃₂	4	5/8	17.6
2 ¹⁵ / ₁₆ 3	RSF-1215 RSF-1300	5 ⁹ / ₁₆	3 ¹³ / ₃₂	6 ⁵ / ₈	7 ³ / ₁₆	1 ¹ / ₁₆	5 ⁵ / ₆₄	3 ¹⁵ / ₁₆	3 ³ / ₈	4 ³ / ₆₄	1 ⁹ / ₆₄	4	3/4	26.4
3 ⁷ / ₁₆	RSF-1307	6 ²³ / ₃₂	3 ²⁷ / ₃₂	7 ⁵ / ₈	8 ³ / ₈	1 ⁹ / ₃₂	2 ⁹ / ₃₂	4 ³ / ₄	3 ³¹ / ₃₂	4 ⁴⁹ / ₆₄	3/8	4	3/4	38.5
3 ¹⁵ / ₁₆	RSF-1315	7 ¹⁹ / ₃₂	4 ⁷ / ₁₆	8 ³ / ₈	9 ¹ / ₂	1 ³ / ₁₆	7/8	5 ³ / ₈	4 ⁹ / ₁₆	5 ⁵ / ₈	1/2	4	1	53.9

▲Length along shaft.

#Dimensions for fixed bearings. For expansion bearings add 1/8 inch maximum.

Add EX suffix for expansion bearings with 1/8 inch movement (example RSF1215EX)

**Interchange guide is for comparison only.

RSDP ADAPTER MOUNT

Mill Duty Bearings

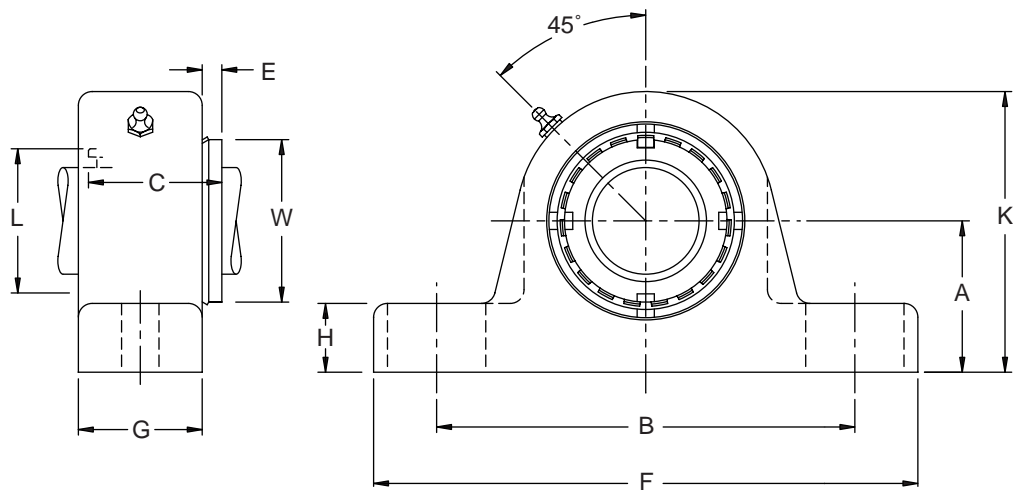

TWO BOLT

Shaft Size Inches	Complete Fixed Bearing Block No.	Dimension in Inches											Bolts		Complete Block Net Wt. Lbs.
		A	B		C [▲]	E [#]	F [*]	G	H	K	L	W	No.	Size	
		±0.005	Min	Max											
TWO BOLT HOUSINGS															
1 ⁵ / ₁₆	RSDP-8115	2 ¹ / ₄	6	7 ¹ / ₈	2 ²³ / ₆₄	5 ⁵ / ₁₆	8 ⁷ / ₈	2 ¹ / ₄	1 ¹ / ₄	4 ³ / ₄	5 ⁵ / ₈	2 ⁶¹ / ₆₂	2	5 ⁵ / ₈	14.3
2 ³ / ₁₆	RSDP-8203	2 ¹ / ₂	6 ¹ / ₂	7 ⁷ / ₈	2 ²³ / ₃₂	7 ¹ / ₁₆	9 ⁵ / ₈	2 ¹ / ₂	1 ³ / ₈	5 ¹ / ₄	3 ³ / ₃₂	3 ¹¹ / ₃₂	2	5 ⁵ / ₈	16.5
2 ⁷ / ₁₆ 2 ¹ / ₂	RSDP-8207 RSDP-8208	2 ³ / ₄	6 ⁷ / ₈	8 ⁵ / ₈	3 ¹ / ₃₂	4 ¹ / ₆₄	10 ¹ / ₄	2 ⁹ / ₁₆	1 ¹ / ₂	5 ³ / ₄	3 ³ / ₈	3 ⁵⁵ / ₆₄	2	5 ⁵ / ₈	20.9
2 ¹⁵ / ₁₆ 3	RSDP-8215 RSDP-8300	3 ¹ / ₄	7 ⁷ / ₈	9 ⁵ / ₈	3 ¹¹ / ₃₂	4 ⁵ / ₆₄	11 ⁵ / ₈	2 ¹³ / ₁₆	1 ¹¹ / ₁₆	6 ⁵ / ₈	3 ³¹ / ₃₂	4 ²¹ / ₆₄	2	3 ³ / ₄	26.4
3 ⁷ / ₁₆	RSDP-8307	3 ³ / ₄	9 ³ / ₈	11 ¹ / ₄	4 ¹ / ₃₂	6 ³ / ₆₄	13 ¹ / ₂	3 ¹ / ₈	1 ⁷ / ₈	8	4 ⁹ / ₁₆	5 ¹ / ₈	2	7 ⁷ / ₈	40.7
3 ¹⁵ / ₁₆	RSDP-8315	4 ¹ / ₄	10 ¹ / ₁₆	12 ¹ / ₂	4 ¹³ / ₆₄	1 ⁷ / ₃₂	14 ¹ / ₄	4 ⁵ / ₃₂	2	8 ³ / ₄	5 ¹ / ₃₂	5 ⁴⁵ / ₆₄	2	1	49.5

▲Length along shaft.

#Dimensions for fixed bearings. For expansion bearings add 1/8 inch maximum.

*Length along base is machined.

Add EX suffix for expansion bearings with 1/8 inch movement (example RSDP8215EX)

**Interchange guide is for comparison only.

RSDR ADAPTER MOUNT

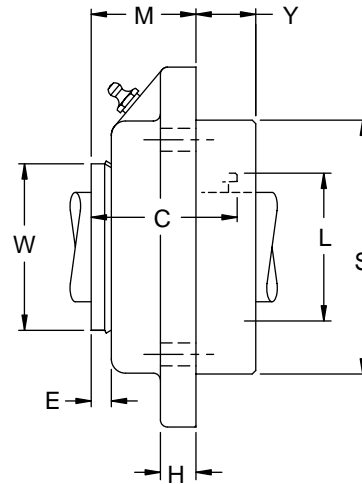
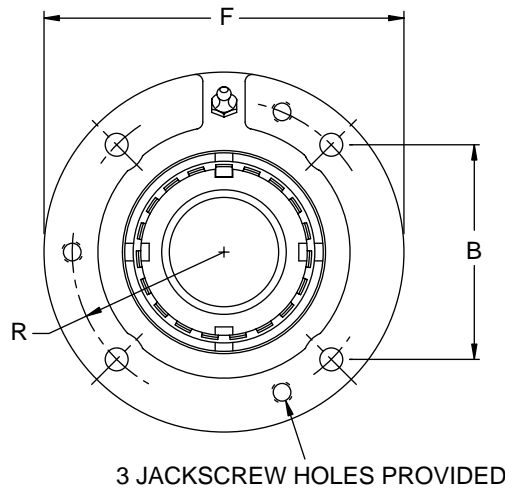

Shaft Size Inches	Complete Fixed Bearing Block No.	Dimension in Inches											Bolts		Complete Block Net Wt. Lbs.	
		B	C [▲]	E [#]	F	H	M	R	S +0.000 -0.002	L	W	Y	No.	Size		
FOUR BOLT HOUSING																
1 ¹⁵ / ₁₆	RSDR-8115	3 ⁵¹ / ₆₄	2 ²³ / ₆₄	9/ ₃₂	6 ³ / ₈	1/2	1 ³⁹ / ₆₄	2 ¹¹ / ₁₆	4 ¹ / ₂	2 ⁵ / ₈	2 ⁶¹ / ₆₂	1	4	3/ ₈	15.4	
2 ³ / ₁₆	RSDR-8203	4 ¹ / ₄	2 ²³ / ₃₂	2 ¹ / ₆₄	7 ¹ / ₈	1 ³ / ₁₆	1 ³¹ / ₃₂	3	5	3 ³ / ₃₂	3 ¹¹ / ₃₂	1	4	1/2	19.8	
2 ⁷ / ₁₆ 2 ¹ / ₂	RSDR-8207 RSDR-8208	4 ¹⁹ / ₃₂	3 ¹ / ₃₂	1 ⁵ / ₃₂	7 ⁵ / ₈	1 ³ / ₁₆	2 ¹ / ₁₆	3 ¹ / ₄	5 ¹ / ₂	3 ³ / ₈	3 ⁵⁵ / ₆₄	1 ¹ / ₄	4	1/2	24.2	
2 ¹⁵ / ₁₆ 3	RSDR-8215 RSDR-8300	5 ¹⁹ / ₆₄	3 ¹¹ / ₃₂	4 ³ / ₆₄	8 ³ / ₄	1 ¹ / ₁₆	2 ¹ / ₈	3 ³ / ₄	6 ³ / ₈	3 ³¹ / ₃₂	4 ²¹ / ₆₄	1 ³ / ₈	4	5/ ₈	42.9	
3 ⁷ / ₁₆	RSDR-8307	6 ³ / ₃₂	4 ¹ / ₃₂	1 ⁵ / ₁₆	10 ¹ / ₄	1 ¹ / ₈	2 ¹³ / ₁₆	4 ⁵ / ₁₆	7 ³ / ₈	4 ⁹ / ₁₆	5 ¹ / ₈	1 ³ / ₈	4	3/ ₄	57.2	
3 ¹⁵ / ₁₆	RSDR-8315	6 ⁵ / ₈	4 ¹³ / ₆₄	5/ ₈	10 ⁷ / ₈	7/ ₈	2 ²⁹ / ₃₂	4 ¹¹ / ₁₆	8 ¹ / ₈	5 ¹ / ₃₂	5 ⁴⁵ / ₆₄	1 ¹ / ₂	4	3/ ₄	71.5	
4 ⁷ / ₁₆	RSDR-8407	8 ⁵ / ₁₆	5 ¹³ / ₆₄	1 1/ ₆₄	13 ¹ / ₂	1	3 ¹ / ₄	5 ⁷ / ₈	10 ¹ / ₄	5 ³ / ₄	6 ⁹ / ₁₆	1 ²⁹ / ₃₂	4	3/ ₄	94.5	

▲Length along shaft.

#Dimensions for fixed bearings. For expansion bearings add 1/8 inch maximum.

Add EX suffix for expansion bearings with 1/8 inch movement (example RSDR8215EX)

**Interchange guide is for comparison only.



RSDF ADAPTER MOUNT

Mill Duty Bearings

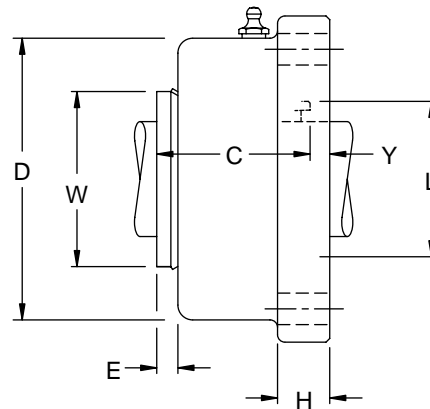
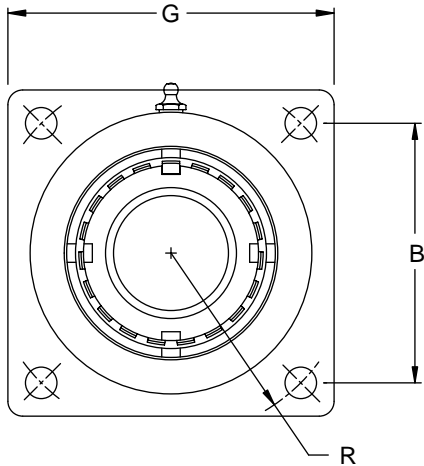

Shaft Size Inches	Complete Fixed Bearing Block No.	Dimension in Inches										Bolts		Complete Block Net Wt. Lbs.
		B	C [▲]	D	G	H	E [#]	R	L	W	Y	No.	Size	
1 ¹⁵ / ₁₆	RSDF-8115	4 ³ / ₈	2 ²³ / ₆₄	4 ⁷ / ₈	5 ¹ / ₂	7 ⁷ / ₈	1 ¹¹ / ₆₄	3 ³ / ₃₂	2 ⁵ / ₈	2 ⁶¹ / ₆₂	3 ³ / ₈	4	1 ¹ / ₂	13.2
2 ³ / ₁₆	RSDF-8203	4 ⁷ / ₈	2 ²³ / ₃₂	5 ⁷ / ₁₆	6 ³ / ₁₆	1	2 ³ / ₆₄	3 ²⁹ / ₆₄	3 ³ / ₃₂	3 ¹¹ / ₃₂	1 ⁷ / ₆₄	4	5 ⁵ / ₈	16.5
2 ⁷ / ₁₆ 2 ¹ / ₂	RSDF-8207 RSDF-8208	5 ³ / ₈	3 ¹ / ₃₂	5 ¹⁵ / ₁₆	6 ⁵ / ₈	1	3 ³⁵ / ₆₄	3 ⁵¹ / ₆₄	3 ³ / ₈	3 ⁵⁵ / ₆₄	2 ¹ / ₆₄	4	5 ⁵ / ₈	19.8
2 ¹⁵ / ₁₆ 3	RSDF-8215 RSDF-8300	6	3 ¹¹ / ₃₂	6 ³ / ₄	7 ⁷ / ₁₆	1 ¹ / ₈	2 ³ / ₃₂	4 ¹ / ₄	3 ³¹ / ₃₂	4 ²¹ / ₆₄	7 ⁷ / ₃₂	4	3 ³ / ₄	30.8
3 ⁷ / ₁₆	RSDF-8307	7	4 ¹ / ₃₂	7 ⁵ / ₈	8 ⁵ / ₈	1 ⁵ / ₁₆	2 ⁷ / ₃₂	4 ⁶¹ / ₆₄	4 ⁹ / ₁₆	5 ¹ / ₈	1 ¹ / ₈	4	3 ³ / ₄	42.9
3 ¹⁵ / ₁₆	RSDF-8315	7 ³ / ₄	4 ¹³ / ₆₄	8 ³ / ₄	10	1 ¹ / ₂	3 ⁷ / ₆₄	5 ³¹ / ₆₄	5 ¹ / ₃₂	5 ⁴⁵ / ₆₄	7 ⁷ / ₁₆	4	7 ⁷ / ₈	58.3

▲Length along shaft.

#Dimensions for fixed bearings. For expansion bearings add 1/8 inch maximum.

Add EX suffix for expansion bearings with 1/8 inch movement (example RSDF8215EX)

**Interchange guide is for comparison only.

RSSN ADAPTER MOUNT

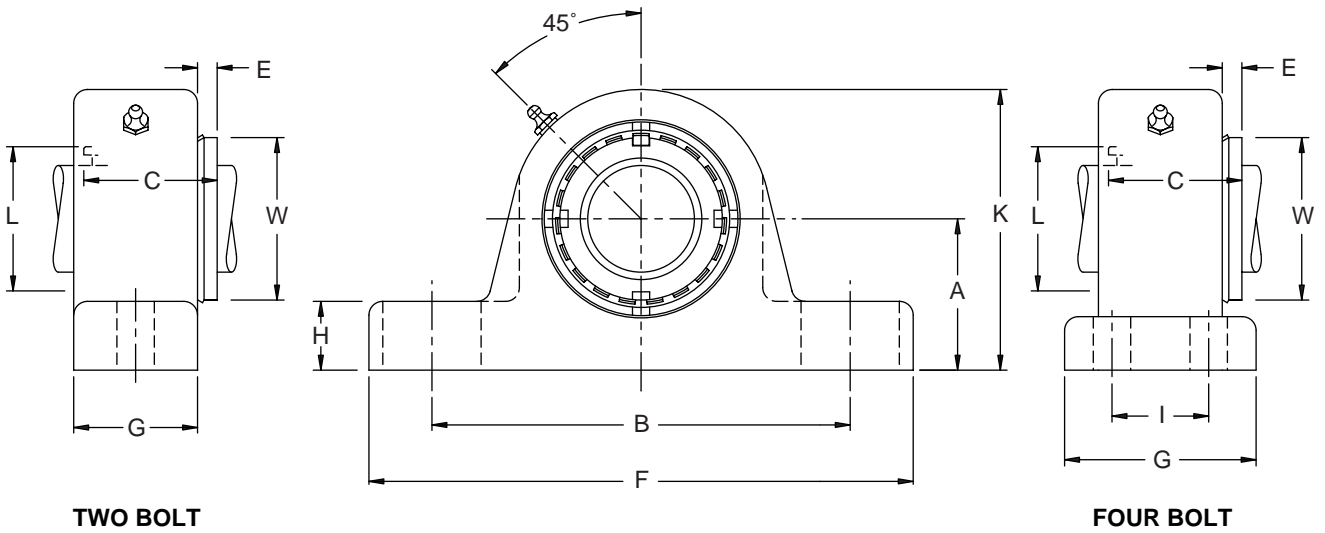

Shaft Size Inches	Complete Fixed Bearing Block No.	Dimension in Inches												Bolts		Complete Block Net Wt. Lbs.
		A ±0.005	B		C [▲]	E [#]	F [*]	G	H	I	K	L	W	No.	Size	
			Min	Max												
TWO BOLT HOUSINGS																
1 ¹⁵ / ₁₆	RSSN-8115	2.750	6.50	8.70	2.36	0.33	9.88	2.72	1.25	...	5.15	2.62	2.95	2	5/8	16.5
2 ³ / ₁₆	RSSN-8203	3.150	7.20	9.20	2.72	0.43	10.31	3.27	1.38	...	5.97	3.10	3.35	2	5/8	22.0
2 ⁷ / ₁₆ 2 ¹ / ₂	RSSN-8207 RSSN-8208	3.150	7.88	9.63	3.03	0.62	10.88	2.55	1.40	...	6.28	3.37	3.86	2	5/8	25.3
2 ¹⁵ / ₁₆ 3	RSSN-8215 RSSN-8300	3.740	9.50	10.88	3.34	0.71	12.48	2.75	1.68	...	7.24	3.97	4.33	2	3/4	38.5
FOUR BOLT HOUSINGS																
3 ⁷ / ₁₆	RSSN-8307F	4.409	10.88	13.38	4.03	0.81	15.00	4.31	1.78	2.38	8.72	4.56	5.13	4	3/4	64.9
3 ¹⁵ / ₁₆	RSSN-8315F	4.921	11.88	14.50	4.20	0.62	16.00	4.75	1.98	2.75	9.70	5.03	5.70	4	3/4	82.5
4 ⁷ / ₁₆	RSSN-8407F	5.906	14.00	14.75	5.20	0.62	17.50	5.13	1.91	3.19	11.54	5.75	6.56	4	1	118.8

▲Length along shaft.

#Dimensions for fixed bearings. For expansion bearings add 1/8 inch maximum.

*Length along base is machined.

Add EX suffix for expansion bearings with 1/8 inch movement (example RSSN8215EX)

**Interchange guide is for comparison only.

ECCENTRIC LOCK BEARINGS 1000 SERIES

1. Inspect shaft - The shaft should be clean, free of nicks and within the recommended size. The recommended size is from nominal to -.001 inch for average applications. Applications that have very high loads/shock may require a light press fit. The shaft can be coated with grease or oil to ease assembly.
2. Position the bearings on the shaft by applying all driving pressure to the face of the inner race. If it is necessary to use force, drive on the inner race with a soft punch. Do not drive on the housing.
3. Align and bolt all housings securely to the mounting support.
4. On the fixed bearing only (closest to the drive) slide the collar over the inner race cam. Rotate the collar in the direction of shaft rotation until snug. Utilizing a hammer and punch rotate the collar until tight.
5. Tighten the setscrews per the setscrew torque table. Generally the Allen wrench will begin to twist at the proper torque value.
6. Do not secure the remaining bearings to the shaft at this time unless you are using one fixed and one floating bearing. You may need to secure the collars to the shaft if they must be on the shaft.
7. Rotate the shaft under power to permit the remaining bearings to seek their natural running position. This should be done for 2-3 minutes if using two fixed bearings.
8. Shut off the power and mount the other bearings per steps four and five.

ADAPTER BEARINGS 8000 SERIES

1. Inspect shaft - The shaft should be clean, free of nicks and within the recommended size. The recommended size is from nominal to -.005 inch for average applications. The shaft can be coated with grease or oil to ease assembly.
2. Rotate the adapter sleeve nut counter-clockwise and tap the nut/sleeve back into the inner race bore. This will expand the bore making it easier to install. Do not expand the bore more than necessary.
3. Position both bearings loosely on the shaft and align as necessary.
4. On the fixed bearing only (closest to the drive) secure/mount the housing and then the inner race. Rotate the adapter nut clockwise until the adapter sleeve/nut is snug; (zero clearance is achieved by rotating the nut with a spanner wrench hand tight) then rotate/drive the adapter nut the indicated amount shown in the table below. Ensure the nut rotates the correct amount relative to the sleeve by marking the shaft, sleeve, and nut with a grease/paint pen.
5. Recheck shaft position for accuracy and mount the floating bearing within the expansion travel as necessary. Be careful not to create a thrust preload when the inner race is secured to the shaft. If the bearing is a pillow block, this may be checked by looking for axial housing movement when the mounting bolts are loose.
6. Bend the tanged washer into the nuts as necessary. It may be necessary to tighten the locknut slightly but never loosen the locknut during this procedure.

GENERAL INSTALLATION COMMENTS

1. Mounted units are prelubricated at the factory with NLGI grade 2 lithium complex grease. No additional grease is required at time of installation. Relubrication frequency can be found on the back of this page.
2. Position housings for accessibility of grease fittings. Heavy thrust loads should be loaded against the shoulder side of the housing, not against the threaded cover side.
3. Shaft shoulders are recommended to support vertical shafts and high thrust loads.
4. When pillow blocks are mounted on an inclined plane or the work forces is parallel with the base, either lateral bolts or welded stop blocks should be used to prevent shifting.
5. Avoid direct hammer blows to the bearing by using a soft drift or wood block.
6. New seals should be used whenever a bearing is rebuilt.
7. S.A.E. bolts grade 5 or 8 can be used on steel housings.
8. If using two adapter bearings on a shaft it is generally recommended to use one fixed and one floating bearing.
9. It is generally good practice to rotate the shaft by hand to check for binding, noise, or bent shaft before restarting the equipment.
10. After the equipment has run for some time it is good to check/monitor the bearing for evidence of excessive heat, noise, or vibration.

SET SCREW TORQUE TABLE

Shaft Size	Set Screw Size	Torque Value (Inch-Pounds)
1 ¹⁵ / ₁₆ to 2	3/8	225
2 ³ / ₁₆ to 4	7/16	325

LOCKNUT TIGHTENING TABLE

Shaft Size	Final Locknut Adjustment
1 ¹⁵ / ₁₆ to 2 ¹ / ₄	1/4 Turn
2 ⁷ / ₁₆ to 2 ¹ / ₂	1/3 Turn
2 ¹⁵ / ₁₆ to 3 ¹⁵ / ₁₆	3/8 Turn
3 ¹⁵ / ₁₆ to 4	1/2 Turn
4 ⁷ / ₁₆ to 4 ¹ / ₂	5/8 Turn

DISASSEMBLY

1. Remove the snap rings and seals.
2. Remove the two radial set screws from the housing at the threaded cover side.
3. Remove the threaded cover by rotating it counter-clockwise.
4. Place housing cover side down on press. Support the housing with spacer blocks and push on the inner race. This will push the entire bearing from the housing.

RE-ASSEMBLY

1. Clean and inspect housing for damage.
2. Slide/push the new bearing into the housing. Push only on the outer race until it seats against the housing back wall.
3. Install threaded cover until it resists rotation.
FIXED BEARING—Tighten threaded cover firmly and install the two radial set screws through the housing. Torque the set screws to 90 inch pounds.
FLOATING BEARING—Tighten the threaded cover firmly and then rotate counter-clockwise 1.5 turns. Install the two radial set screws and torque to 90 inch pounds. Check that the bearing floats/moves in the housing as needed.
4. Install the two seals with the lips on the inside of the bearing.
5. Install the two snap rings with the ends of the snap rings around the raised nib on the seal.
6. Fill the bearing with the initial amount of grease found in the lubrication table below.

LUBRICATION INSTRUCTIONS

All standard bearings come prelubricated from the factory with Mobil Mobilith AW2 grease. Mobilith AW2 is an N.L.G.I. grade 2 grease with a lithium complex thickener. It can be used in most applications at temperatures from -40 to 250° F. For high speeds or other special conditions consult your local Rexnord representative or the Rex Bearing engineering department. At high temperature, greases/oils degrade more rapidly and thus require fresh grease more frequently. In general, small amounts of grease added frequently provide better lubrication. Automatic lubricators can provide a consistent supply of fresh grease when properly specified. If equipment will not be in operation for some time, please contact Rexnord Bearing for recommended storage protection.

Relubrication

Bearings should be relubricated at regular intervals. The type of service will determine the frequency and amount of lubricant. General guidelines for relubrication are based upon average applications and can be found below.

Mixing of different greases

The mixing of different types of grease can cause complete breakdown of the lubrication. Mixing of incompatible lubrication types can cause early bearing failures. The mixing of any two greases should be checked with the lubricant manufacturer. The base material or thickener type is usually used to identify the compatibility of different greases. Do not mix greases with different thickener types without checking the compatibility of those greases.

WARNING:

The reliability of all Mill Duty bearings can be realized in service only when they are correctly selected and properly installed, protected and maintained. The correct bearing selection requires the magnitude and nature of all loads, speeds, alignment, mounting, operating requirements, and maintenance be adequately considered. The design and material selection for housings, shafting, fasteners, seals, and accessories as well as provisions for installation and maintenance must follow good engineering principles.

Housings and threaded rings must be designed to safely handle the radial and axial loads involved. Adequate space must be provided in the housing and threaded rings for a supply of lubricant. Seals must be selected that will satisfactorily cope with the environmental conditions. Shaft O.D. size must meet recommended fitting practices, and should be followed strictly to assure a successful mounting arrangement.

These instructions provide detailed information to aid in proper installation, operation, and maintenance, and should be carefully read and followed. Failure to do so may result in unsatisfactory service as well as serious personal injury or property damage.

LUBRICATION TABLE

Shaft Size (Inches)		Grease Required (oz.)		Recommended Number of Months Between Relubrication (based on 40 hr. wk.)				
ECCENTRIC LOCK	ADAPTER	Initial Fill	To Relube Units	RPM				
1000 SERIES	8000 SERIES			100	300	500	1000	1750
1 ¹⁵ / ₁₆ to 2	—	0.9	0.2	8	5	3	1	1/2
2 ³ / ₁₆ to 2 ¹ / ₄	1 ¹⁵ / ₁₆ to 2	1.1	0.2					
2 ⁷ / ₁₆ to 2 ¹ / ₂	2 ³ / ₁₆ to 2 ¹ / ₄	1.5	0.3					
2 ¹⁵ / ₁₆ to 3	2 ⁷ / ₁₆ to 2 ¹ / ₂	2.8	0.5					
3 ⁷ / ₁₆ to 3 ¹ / ₂	2 ¹⁵ / ₁₆ to 3	3.7	0.6	6	4	2	1	1/2
3 ¹⁵ / ₁₆ to 4	3 ⁷ / ₁₆ to 3 ¹ / ₂	6.9	1.1					
—	3 ¹⁵ / ₁₆ to 4	8.4	1.5					
—	4 ⁷ / ₁₆ to 4 ¹ / ₂	14.3	2.5	4	2	1	1/2	—

BEARING SERIES		LOAD RATING Lbs		MAX RPM	LIFE IN HOURS	RADIAL LOAD RATING TABLE (LBS)														
						SPEED (RPM)														
1000	8000	C	C ₀			50	100	200	350	500	750	1000	1250	1500	1750	2000	2500	3000		
1115		22000	25500	3200	5000	*	*	*	5446	4893	4333	3975	3717	3519	3360	3228				
					15000	*	*	4633	3917	3519	3116	2859	2673	2531	2417	2322	2172			
					80000	4250	3452	2804	2370	2130	1886	1730	1618	1532	1463	1405	1314	1244		
1203	8115	27000	32500	2900	5000	*	*	*	6684	6005	5318	4878	4562	4319	4124					
					15000	*	*	5686	4807	4319	3824	3508	3281	3106	2966	2850				
					80000	5216	4236	3441	2909	2614	2315	2123	1986	1880	1795	1725	1613			
1207 1208	8203	38000	46500	2400	5000	*	*	*	9406	8452	7484	6865	6421	6079						
					15000	*	*	8002	6765	6079	5383	4938	4618	4372	4174					
					80000	7340	5962	4843	4094	3679	3258	2988	2795	2646	2526	2427				
1215 1300	8207 8208	41500	53000	2200	5000	*	*	*	10273	9230	8173	7497	7012	6639						
					15000	*	*	8739	7388	6639	5878	5392	5043	4775	4559					
					80000	8016	6511	5289	4472	4018	3558	3263	3052	2890	2759	2651				
	8215 8300	58500	73500	1900	5000	*	*	*	14481	13012	11521	10569	9884							
					15000	*	*	12319	10415	9358	8286	7601	7109	6731						
					80000	11300	9179	7455	6303	5664	5015	4600	4302	4073	3889					
1307		64000	81500	1800	5000	*	*	*	15842	14235	12604	11562	10814							
					15000	*	*	13477	11394	10238	9065	8316	7777	7363						
					80000	12363	10042	8156	6896	6196	5486	5033	4707	4456	4255					
1315	8307	80000	104000	1600	5000	*	*	*	19803	17794	15756	14453								
					15000	*	*	16846	14243	12798	11332	10395	9722							
					80000	15453	12552	10196	8620	7745	6858	6291	5884	5570						
	8315	102000	132000	1450	5000	*	*	*	25249	22687	20088									
					15000	*	*	21479	18160	16317	14448	13253								
					80000	19703	16004	12999	10990	9875	8744	8021	7502							
	8407	143000	196000	1250	5000	*	*	*	35398	31806										
					15000	*	*	30113	25459	22876	20256									
					80000	27623	22437	18224	15408	13844	12259	11245								

*Load Exceeds 25% of C rating, Consult Rexnord

Values in the table represent the 8000 Series bearings or press fit mounting of the 1000 Series bearings. When slip fits or clearance mounting are used the table values should be reduced up to 10% for the 1000 Series bearings.

THEORETICAL BEARING LIFE CALCULATION

Bearing life is defined as the number of revolutions (or hours) that 90% of a group of bearings will meet or exceed before evidence of raceway spalling occurs. The life can be calculated by using the following empirical formula.

$$\text{Life in hours} = \frac{(1 \times 10^6)}{(60 \times \text{RPM})} \left[\frac{C}{P_e} \right]^{10/3}$$

For applications that have combined radial and thrust loads the appropriate formula listed below must be used to calculate the Pe. Pe = equivalent radial load. Pr = Radial load. Pt = Thrust load. C = Dynamic load rating. C₀ = Static capacity.

THRUST TABLE		
Shaft Size		Combined Radial and Thrust load
1000 SERIES	8000 SERIES	
1 ¹⁵ / ₁₆ THRU 2 ⁷ / ₁₆	1 ¹⁵ / ₁₆ THRU 3 ³ / ₁₆	If the thrust load is less than 23% of the radial load Pe = Pr + 2.92Pt
		If the thrust load is more than 23% of the radial load Pe = .67Pr + 4.35Pt
2 ¹⁵ / ₁₆ THRU 3 ¹⁵ / ₁₆	2 ⁷ / ₁₆ THRU 3 ⁷ / ₁₆	If the thrust load is less than 22% of the radial load Pe = Pr + 3.04Pt
		If the thrust load is more than 22% of the radial load Pe = .67Pr + 4.53Pt
NONE	3 ¹⁵ / ₁₆ THRU 4 ⁷ / ₁₆	If the thrust load is less than 25% of the radial load Pe = Pr + 2.71Pt
		If the thrust load is more than 25% of the radial load Pe = .67Pr + 4.04Pt



1000 SERIES ECCENTRIC MOUNT BEARING KIT



ECCENTRIC COLLAR



SEAL KIT



8000 SERIES ADAPTER MOUNT BEARING KIT



ADAPTER KIT



COVER KIT

REPLACEMENT KITS - 1000 SERIES

Shaft size Inches	1000 Series Bearing w/ collar & setscrews	Collar w/ setscrews	Seal w/ snap ring (2 each per kit)	Cover w/ setscrews
1 ¹⁵ / ₁₆	1115U	SC1115	RS1200	TC1200
2 ³ / ₁₆	1203U	SC1203	RS1204	TC1204
2 ⁷ / ₁₆	1207U	SC1207	RS1208	TC1208
2 ¹ / ₂	1208U	SC1208		
2 ¹⁵ / ₁₆	1215U	SC1215	RS1300	TC1300
3	1300U	SC1300		
3 ⁷ / ₁₆	1307U	SC1307	RS1308	TC1308
3 ¹⁵ / ₁₆	1315U	SC1315	RS1400	TC1400

REPLACEMENT KITS - 8000 SERIES

Shaft size Inches	8000 Series Bearing w/ adapter assembly	Adapter assembly	Seal w/ snap ring (2 each per kit)	Cover w/ setscrews
1 ¹⁵ / ₁₆	8115KU	AK8115K	RS1204	TC1204
2 ³ / ₁₆	8203KU	AK8203K	RS1208	TC1208
2 ⁷ / ₁₆	8207KU	AK8207K	RS1300	TC1300
2 ¹ / ₂	8208KU	AK8208K		
2 ¹⁵ / ₁₆	8215KU	AK8215K	RS1308	TC8300
3	8300KU	AK8300K		
3 ⁷ / ₁₆	8307KU	AK8307K	RS1400	TC1400
3 ¹⁵ / ₁₆	8315KU	AK8315K	RS8400	TC8400
4 ⁷ / ₁₆	8407KU	AK8407K	RS8408	TC8408



World Class Customer Service

For over 100 years the dedicated people of Rexnord have delivered excellence in quality and service to our customers around the globe. Rexnord is a trusted name when it comes to providing skillfully engineered products that improve productivity and efficiency for industrial applications worldwide. We are committed to exceeding customer expectations in every area of our business: product design, application engineering, operations and customer service.

Because of our customer focus, we are able to more thoroughly understand the needs of your business and have the resources available to work closely with you to reduce maintenance costs, eliminate redundant inventories and prevent equipment down time.

Rexnord represents the most comprehensive portfolio of power transmission and conveying components in the world with the brands you know and trust.

The Power of Rexnord™



FLATTOP

BEARINGS

GEARED
PRODUCTSINDUSTRIAL
CHAIN

COUPLINGS

AEROSPACE

SPECIAL
COMPONENTS

WORLDWIDE CUSTOMER SERVICE

AUSTRALIA

Rexnord Australia Pty. Ltd.
Picton, New South Wales
Phone: 61.2.4677.3811
Fax: 61.2.4677.3812

BRAZIL

Rexnord Correntes Ltda.
Sao Leopoldo - RS
Phone: 55.51.579.8022
Fax: 55.51.579.8029

CANADA

Rexnord Canada Ltd.
Scarborough, Ontario
Phone: 1.416.297.6868
Fax: 1.416.297.6873

CHINA

Rexnord China
Shanghai, China
Phone: 86.21.62701942
Fax: 86.21.62701943

EUROPE

Rexnord NV/SA
Mechelen, Belgium
Phone: 32.70.22.33.66
Fax: 32.70.22.33.67

Rexnord Kette GmbH
Betzdorf, Germany
Phone: 49.2741.2840
Fax: 49.2741.284.385

LATIN AMERICA

Rexnord International, Inc.
Milwaukee, Wisconsin
Phone: 1.414.643.3000
Fax: 1.414.643.3222

MEXICO

Rexnord S.A. de C.V.
Queretaro, Qro.
Phone: 52.442.218.5000
Fax: 52.442.218.1090

SINGAPORE

Rexnord International, Inc.
Singapore City, Singapore
Phone: 65.6338.5622
Fax: 65.6338.5422

UNITED STATES

Eastern Service Center
Atlanta, Georgia
Phone: 1.770.431.7200
Fax: 1.770.431.7299

Central Service Center
Grove City, Ohio
Phone: 1.614.675.1800
Fax: 1.614.675.1898

Southern Service Center
Arlington, Texas
Phone: 1.817.385.2800
Fax: 1.817.385.2873



Rexnord Bearing Group
7601 Rockville Road
Indianapolis, Indiana 46214
Phone: 1.317.273.5500 Fax: 1.317.273.5620
Visit us on-line at www.rexnord.com